

## 6-Bit Universal Up/Down Counter

The MC10E/100E136 is a 6-bit synchronous, presettable, cascadable universal counter. The device generates a look-ahead-carry output and accepts a look-ahead-carry input. These two features allow for the cascading of multiple E136's for wider bit width counters that operate at very nearly the same frequency as the stand alone counter.

- 550 MHz Count Frequency
- Fully Synchronous Up and Down Counting
- Internal 75 kΩ Input Pulldown Resistors
- Look-Ahead-Carry Input and Output
- Asynchronous Master Reset
- Extended 100E V<sub>EE</sub> Range of -4.2 V to -5.46 V

The CLOUT output will pulse LOW for one clock cycle one count before the E136 reaches terminal count. The COUT output will pulse LOW for one clock cycle when the counter reaches terminal count. For more information on utilizing the look-ahead-carry features of the device please refer to the applications section of this data sheet. The differential COUT output facilitates the E136's use in programmable divider and self-stopping counter applications.

Unlike the H136 and other similar universal counter designs the E136 carry out and look-ahead-carry out signals are registered on chip. This design alleviates the glitch problem seen on many counters where the carry out signals are merely gated. Because of this architecture there are some minor functional differences between the E136 and H136 counters. The user, regardless of familiarity with the H136, should read this data sheet carefully. Note specifically (see logic diagram) the operation of the carry out outputs and the look-ahead-carry in input when utilizing the master reset.

When left open all of the input pins will be pulled LOW via an input pulldown resistor. The master reset is an asynchronous signal which when asserted will force the Q outputs LOW.

The Q outputs need not be terminated for the E136 to function properly, in fact if these outputs will not be used in a system it is recommended to save power and minimize noise that they be left open. This practice will minimize switching noise which can reduce the maximum count frequency of the device or significantly reduce margins against other noise in the system.

**MC10E136**  
**MC100E136**

**6-BIT UNIVERSAL**  
**UP/DOWN COUNTER**



### PIN NAMES

| Pin                             | Function                               |
|---------------------------------|--|
| D <sub>0</sub> - D <sub>5</sub> | Preset Data Inputs                     |
| Q <sub>0</sub> - Q <sub>5</sub> | Data Inputs                            |
| S1, S2                          | Mode Control Pins                      |
| MR                              | Master Reset                           |
| CLK                             | Clock Input                            |
| COUT, COUT                      | Carry-Out Output (Active LOW)          |
| CLOUT                           | Look-Ahead-Carry Out (Active LOW)      |
| CIN                             | Carry-In Input (Active LOW)            |
| CLIN                            | Look-Ahead-Carry In Input (Active LOW) |

### FUNCTION TABLE (Expanded truth table on page 2-4)

| S1 | S2 | CIN | MR | CLK | Function                     |
|----|----|-----|----|-----|------------------------------|
| L  | L  | X   | L  | Z   | Preset Parallel Data         |
| L  | H  | L   | L  | Z   | Increment (Count Up)         |
| L  | H  | H   | L  | Z   | Hold Count                   |
| H  | L  | L   | L  | Z   | Decrement (Count Down)       |
| H  | L  | H   | L  | Z   | Hold Count                   |
| H  | H  | X   | L  | Z   | Hold Count                   |
| X  | X  | X   | H  | X   | Reset (Q <sub>n</sub> = LOW) |

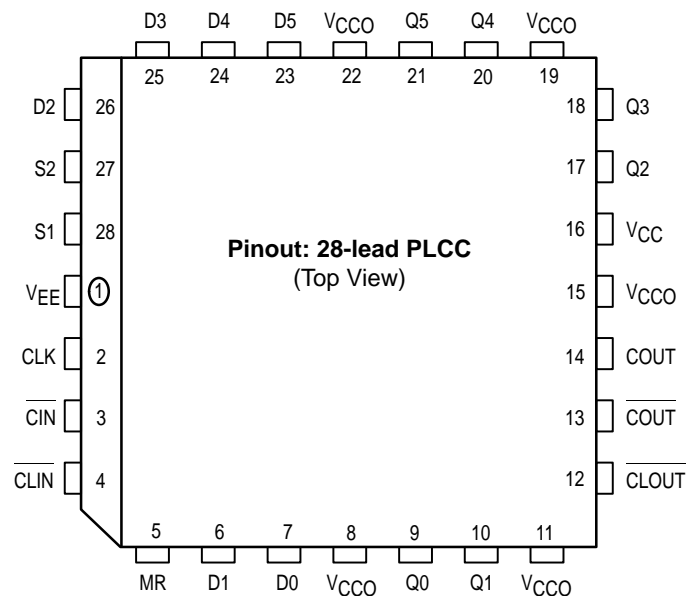

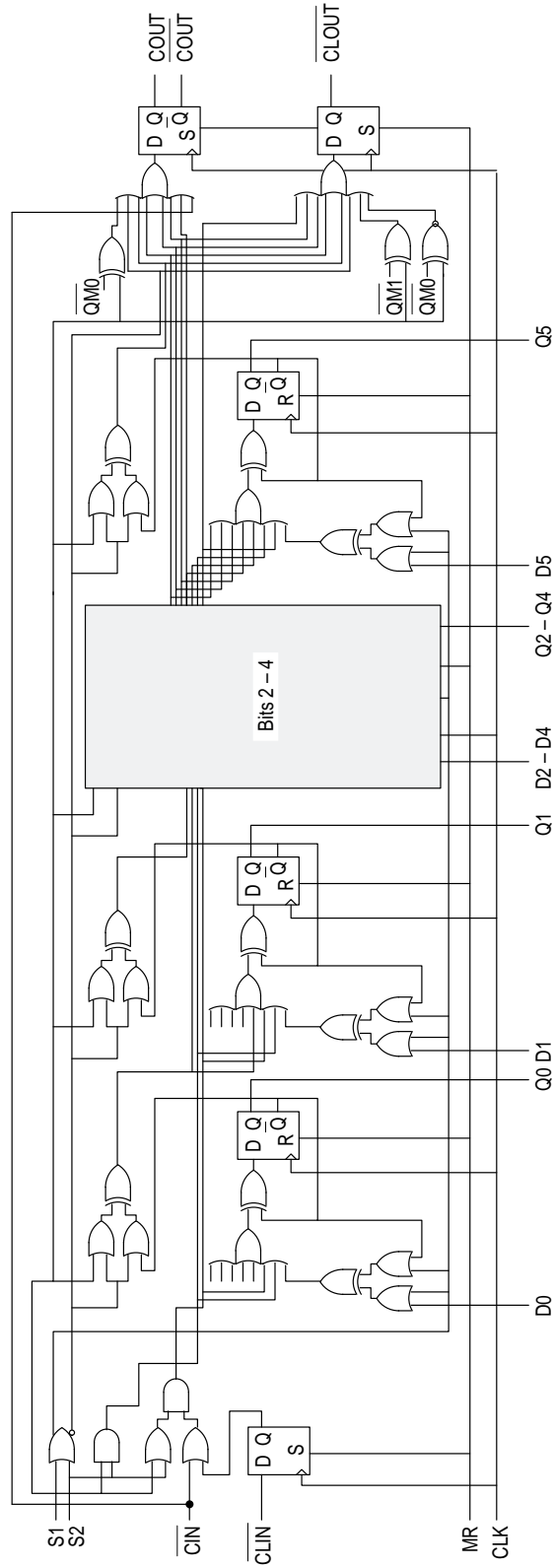

**E136 Universal Up/Down Counter Logic Diagram**

Note that this diagram is provided for understanding of logic operation only. It should not be used for propagation delays as many gate functions are achieved internally without incurring a full gate delay.

## DC CHARACTERISTICS

 $(V_{EE} = V_{EE(min)} \text{ to } V_{EE(max)}; V_{CC} = V_{CCO} = GND)$ 

| Characteristic                      | Symbol   | 0°C    |            |            | 25°C   |            |            | 85°C   |            |            | Unit    | Condition |
|-------------------------------------|----------|--------|------------|------------|--------|------------|------------|--------|------------|------------|---------|-----------|
|                                     |          | Min    | Typ        | Max        | Min    | Typ        | Max        | Min    | Typ        | Max        |         |           |
| Input HIGH Current                  | $I_{IH}$ | —      | —          | 150        | —      | —          | 150        | —      | —          | 150        | $\mu A$ |           |
| Power Supply Current<br>10E<br>100E | $I_{EE}$ | —<br>— | 125<br>125 | 150<br>150 | —<br>— | 125<br>125 | 150<br>150 | —<br>— | 125<br>140 | 150<br>170 | mA      |           |

## AC CHARACTERISTICS

 $(V_{EE} = V_{EE(min)} \text{ to } V_{EE(max)}; V_{CC} = V_{CCO} = GND)$ 

| Characteristic   | Symbol                 | 0°C                       |                              |                              | 25°C                      |                              |                              | 85°C                      |                              |                              | Unit | Condition |
|--|------------------------|---------------------------|------------------------------|------------------------------|---------------------------|------------------------------|------------------------------|---------------------------|------------------------------|------------------------------|------|-----------|
|  |                        | Min                       | Typ                          | Max                          | Min                       | Typ                          | Max                          | Min                       | Typ                          | Max                          |      |           |
| Maximum Count Frequency  | $f_{COUNT}$            | 550                       | 650                          | —                            | 550                       | 650                          | —                            | 550                       | 650                          | —                            | MHz  |           |
| Propagation Delay to Output<br>CLK to Q<br>MR to Q<br>CLK to $\overline{COUT}$<br>CLK to $\overline{COUT}$ | $t_{PLH}$<br>$t_{PHL}$ | 850<br>850<br>800<br>825  | 1150<br>1150<br>1150<br>1150 | 1450<br>1450<br>1300<br>1400 | 850<br>850<br>800<br>825  | 1150<br>1150<br>1150<br>1150 | 1450<br>1450<br>1300<br>1400 | 850<br>850<br>800<br>825  | 1150<br>1150<br>1150<br>1150 | 1450<br>1450<br>1300<br>1400 | ps   |           |
| Setup Time<br>S1, S2<br>D<br>CLIN<br>CIN   | $t_s$                  | 1000<br>800<br>150<br>800 | 650<br>400<br>0<br>400       | —<br>—<br>—<br>—             | 1000<br>800<br>150<br>800 | 650<br>400<br>0<br>400       | —<br>—<br>—<br>—             | 1000<br>800<br>150<br>800 | 650<br>400<br>0<br>400       | —<br>—<br>—<br>—             | ps   |           |
| Hold Time<br>S1, S2<br>D<br>CLIN<br>CIN  | $t_h$                  | 150<br>150<br>300<br>150  | -200<br>-250<br>0<br>-250    | —<br>—<br>—<br>—             | 150<br>150<br>300<br>150  | -200<br>-250<br>0<br>-250    | —<br>—<br>—<br>—             | 150<br>150<br>300<br>150  | -200<br>-250<br>0<br>-250    | —<br>—<br>—<br>—             | ps   |           |
| Reset Recovery Time  | $t_{RR}$               | 1000                      | 700                          | —                            | 1000                      | 700                          | —                            | 1000                      | 700                          | —                            | ps   |           |
| Minimum Pulse Width<br>CLK, MR   | $t_{PW}$               | 700                       | 400                          | —                            | 700                       | 400                          | —                            | 700                       | 400                          | —                            | ps   |           |
| Rise/Fall Times<br>COUT<br>Other   | $t_r$<br>$t_f$         | 275<br>300                | —<br>—                       | 600<br>700                   | 275<br>300                | —<br>—                       | 600<br>700                   | 275<br>300                | —<br>—                       | 600<br>700                   | ps   | 20% - 80% |

EXPANDED TRUTH TABLE

| Function    | S1 | S2 | MR | CIN | CLIN | CLK | D5 | D4 | D3 | D2 | D1 | D0 | Q5 | Q4 | Q3 | Q2 | Q1 | Q0 | COUT | CLOUT |   |
|-------------|----|----|----|-----|------|-----|----|----|----|----|----|----|----|----|----|----|----|----|------|-------|---|
| Preset      | L  | L  | L  | X   | X    | Z   | L  | L  | L  | L  | H  | H  | L  | L  | L  | L  | H  | H  | H    | H     |   |
| Down        | H  | L  | L  | L   | L    | Z   | X  | X  | X  | X  | X  | X  | L  | L  | L  | L  | H  | L  | H    | H     |   |
|             | H  | L  | L  | L   | L    | Z   | X  | X  | X  | X  | X  | X  | L  | L  | L  | L  | L  | L  | H    | L     |   |
|             | H  | L  | L  | L   | L    | Z   | X  | X  | X  | X  | X  | X  | L  | L  | L  | L  | L  | L  | L    | H     |   |
|             | H  | L  | L  | L   | L    | Z   | X  | X  | X  | X  | X  | X  | H  | H  | H  | H  | H  | H  | H    | H     |   |
| Preset      | L  | L  | L  | X   | X    | Z   | H  | H  | H  | H  | L  | L  | H  | H  | H  | H  | L  | L  | H    | H     |   |
| Up          | L  | H  | L  | L   | L    | Z   | X  | X  | X  | X  | X  | X  | H  | H  | H  | H  | L  | H  | H    | H     |   |
|             | L  | H  | L  | L   | L    | Z   | X  | X  | X  | X  | X  | X  | H  | H  | H  | H  | H  | L  | H    | L     |   |
|             | L  | H  | L  | L   | L    | Z   | X  | X  | X  | X  | X  | X  | H  | H  | H  | H  | H  | H  | L    | H     |   |
|             | L  | H  | L  | L   | L    | Z   | X  | X  | X  | X  | X  | X  | L  | L  | L  | L  | L  | L  | L    | H     | H |
|             | L  | H  | L  | L   | L    | Z   | X  | X  | X  | X  | X  | X  | L  | L  | L  | L  | L  | L  | L    | H     | H |
| Hold        | H  | H  | L  | X   | X    | Z   | X  | X  | X  | X  | X  | X  | L  | L  | L  | L  | H  | L  | H    | H     |   |
|             | H  | H  | L  | X   | X    | Z   | X  | X  | X  | X  | X  | X  | L  | L  | L  | L  | H  | L  | H    | H     |   |
| Down Hold   | H  | L  | L  | L   | L    | Z   | X  | X  | X  | X  | X  | X  | L  | L  | L  | L  | L  | H  | H    | L     |   |
|             | H  | L  | L  | L   | L    | Z   | X  | X  | X  | X  | X  | X  | L  | L  | L  | L  | L  | L  | H    | H     |   |
|             | H  | L  | L  | H   | L    | Z   | X  | X  | X  | X  | X  | X  | L  | L  | L  | L  | L  | L  | H    | H     |   |
|             | H  | L  | L  | H   | L    | Z   | X  | X  | X  | X  | X  | X  | L  | L  | L  | L  | L  | L  | L    | H     | H |
|             | H  | L  | L  | H   | H    | Z   | X  | X  | X  | X  | X  | X  | L  | L  | L  | L  | L  | L  | L    | H     | H |
|             | H  | L  | L  | L   | H    | Z   | X  | X  | X  | X  | X  | X  | L  | L  | L  | L  | L  | L  | L    | L     | H |
| Hold        | H  | L  | L  | L   | L    | Z   | X  | X  | X  | X  | X  | X  | L  | L  | L  | L  | L  | L  | L    | H     |   |
|             | H  | L  | L  | L   | L    | Z   | X  | X  | X  | X  | X  | X  | L  | L  | L  | L  | L  | L  | L    | H     |   |
|             | H  | L  | L  | L   | L    | Z   | X  | X  | X  | X  | X  | X  | L  | L  | L  | L  | L  | L  | L    | H     |   |
|             | H  | L  | L  | L   | L    | Z   | X  | X  | X  | X  | X  | X  | L  | L  | L  | L  | L  | L  | L    | L     |   |
| Hold Preset | H  | H  | L  | L   | L    | Z   | X  | X  | X  | X  | X  | X  | L  | L  | L  | L  | L  | L  | L    | H     |   |
|             | L  | L  | L  | X   | X    | Z   | H  | H  | H  | H  | L  | L  | H  | H  | H  | H  | L  | L  | H    | H     |   |
|             | L  | H  | L  | L   | L    | Z   | X  | X  | X  | X  | X  | X  | H  | H  | H  | H  | H  | L  | H    | L     |   |
| Hold Up     | L  | H  | L  | H   | L    | Z   | X  | X  | X  | X  | X  | X  | H  | H  | H  | H  | H  | H  | H    | H     |   |
|             | L  | H  | L  | L   | L    | Z   | X  | X  | X  | X  | X  | X  | H  | H  | H  | H  | H  | H  | H    | L     |   |
| Hold        | L  | H  | L  | H   | L    | Z   | X  | X  | X  | X  | X  | X  | H  | H  | H  | H  | H  | H  | H    | H     |   |
|             | L  | H  | L  | H   | H    | Z   | X  | X  | X  | X  | X  | X  | H  | H  | H  | H  | H  | H  | H    | H     |   |
| Hold        | L  | H  | L  | L   | L    | Z   | X  | X  | X  | X  | X  | X  | H  | H  | H  | H  | H  | H  | H    | L     |   |
|             | L  | H  | L  | L   | L    | Z   | X  | X  | X  | X  | X  | X  | H  | H  | H  | H  | H  | H  | H    | L     |   |
|             | L  | H  | L  | L   | L    | Z   | X  | X  | X  | X  | X  | X  | L  | L  | L  | L  | L  | L  | L    | H     |   |
|             | L  | H  | L  | L   | L    | Z   | X  | X  | X  | X  | X  | X  | L  | L  | L  | L  | L  | L  | L    | H     |   |
| Up          | L  | H  | L  | L   | L    | Z   | X  | X  | X  | X  | X  | X  | L  | L  | L  | L  | L  | L  | H    | H     |   |
|             | L  | H  | L  | L   | L    | Z   | X  | X  | X  | X  | X  | X  | L  | L  | L  | L  | L  | H  | H    | H     |   |
|             | L  | H  | L  | L   | L    | Z   | X  | X  | X  | X  | X  | X  | L  | L  | L  | L  | L  | H  | H    | H     |   |
|             | L  | H  | L  | L   | L    | Z   | X  | X  | X  | X  | X  | X  | L  | L  | L  | L  | L  | H  | H    | H     |   |
| Reset       | X  | X  | H  | X   | X    | X   | X  | X  | X  | X  | X  | X  | L  | L  | L  | L  | L  | L  | H    | H     |   |

Z = Low to High Transition



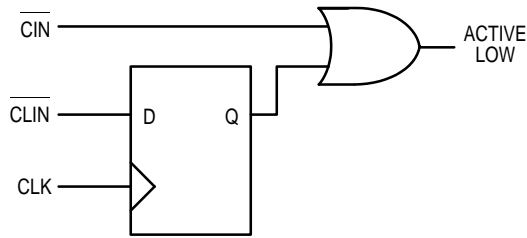
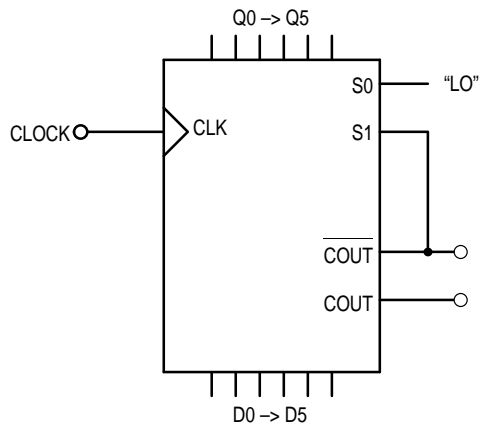

**Figure 2. Look-Ahead-Carry Input Structure**

Note from the waveforms that the look-ahead-carry output (CLOUT) pulses low one clock pulse before the counter reaches terminal count. Also note that both CLOUT and the carry out pin (COUT) of the device pulse low for only one clock period. The input structure for look-ahead-carry in (CLIN) and carry in (CIN) is pictured in Figure 2.

The CLIN input is registered and then ORed with the CIN input. From the truth table one can see that both the CIN and the CLIN inputs must be in a LOW state for the E136 to be enabled to count (either count up or count down). The CLIN inputs are driven by the CLOUT output of the lowest order E136 and therefore are only asserted for a single clock period. Since the CLIN input is registered it must be asserted one clock period prior to the CIN input.

If the counter previous to a given counter is at terminal count its COUT output and thus the CIN input of the given counter will be in the "LOW" state. This signals the given counter that it will need to count one upon the next terminal count of the least significant counter (LSC). The CLOUT output of the LSC will pulse low one clock period before it reaches terminal count. This CLOUT signal will be clocked into the CLIN input of the higher order counters on the following positive clock transition. Since both CIN and CLIN are in the LOW state the next clock pulse will cause the least significant counter to roll over and all higher order counters, if signaled by their CIN inputs, to count by one.



**Figure 3. 6-bit Programmable Divider**

During the clock pulse in which the higher order counter is counting by one the CLIN is clocking in the high signal presented by the CLOUT of the LSC. The CIN's in the higher order counter will ripple propagate through the chain to update the count status for the next occurrence of terminal count on the LSC. This ripple propagation will not affect the count frequency as it has  $2^6-1$  or 63 clock pulses to ripple through without affecting the count operation of the chain.

The only limiting factor which could reduce the count frequency of the chain as compared to a free running single device will be the setup time of the CLIN input. This limit will consist of the CLK to CLOUT delay of the E136 plus the CLIN setup time plus any path length differences between the CLOUT output and the clock.

**Programmable Divider**

Using external feedback of the COUT pin, the E136 can be configured as a programmable divider. Figure 3 illustrates the configuration for a 6-bit count down programmable divider. If for some reason a count up divider is preferred the COUT signal is simply fed back to S2 rather than S1. Examination of the truth table for the E136 shows that when both S1 and S2 are LOW the counter will parallel load on the next positive transition of the clock. If the S2 input is low and the S1 input is high the counter will be in the count down mode and will count towards an all zero state upon successive clock pulses. Knowing this and the operation of the COUT output it becomes a trivial matter to build programmable dividers.

For a programmable divider one wants to load a predesignated number into the counter and count to terminal count. Upon terminal count the counter should automatically reload the divide number. With the architecture shown in Figure 3 when the counter reaches terminal count the COUT output and thus the S1 input will go LOW, this combined with the low on S2 will cause the counter to load the inputs present on D0-D5. Upon loading the divide value into the counter COUT will go HIGH as the counter is no longer at terminal count thereby placing the counter back into the count mode.

**Table 1. Preset Inputs Versus Divide Ratio**

| Divide Ratio | Preset Data Inputs |    |    |    |    |    |
|--------------|--------------------|----|----|----|----|----|
|              | D5                 | D4 | D3 | D2 | D1 | D0 |
| 2            | L                  | L  | L  | L  | L  | H  |
| 3            | L                  | L  | L  | L  | H  | L  |
| 4            | L                  | L  | L  | L  | H  | H  |
| 5            | L                  | L  | L  | H  | L  | L  |
| •            | •                  | •  | •  | •  | •  | •  |
| •            | •                  | •  | •  | •  | •  | •  |
| 36           | H                  | L  | L  | L  | H  | H  |
| 37           | H                  | L  | L  | H  | L  | L  |
| 38           | H                  | L  | L  | H  | L  | H  |
| •            | •                  | •  | •  | •  | •  | •  |
| •            | •                  | •  | •  | •  | •  | •  |
| 62           | H                  | H  | H  | H  | L  | H  |
| 63           | H                  | H  | H  | H  | H  | L  |
| 64           | H                  | H  | H  | H  | H  | H  |

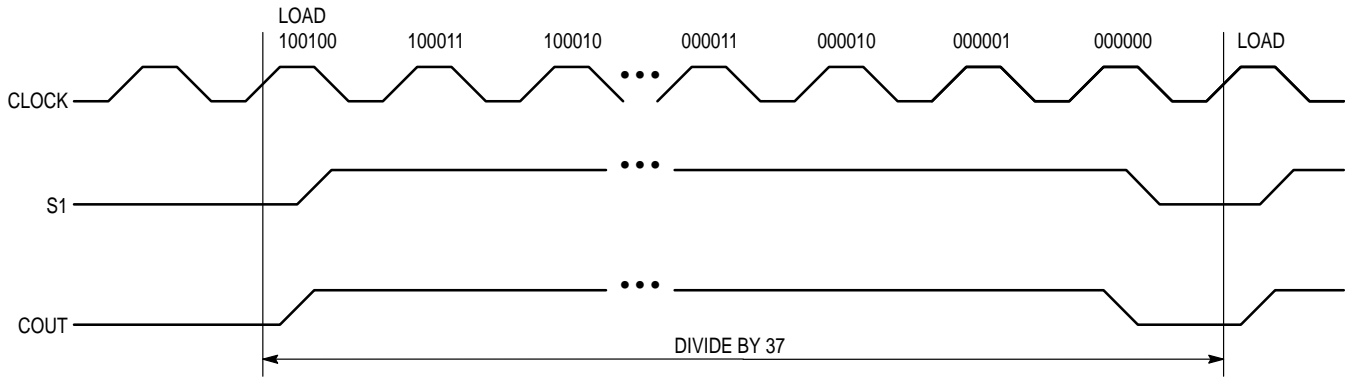

Figure 4. Programmable Divider Waveforms

The exercise of building a programmable divider then becomes simply determining what value to load into the counter to accomplish the desired division. Since the load operation requires a clock pulse, to divide by N, N-1 must be loaded into the counter. A single E136 device is capable of divide ratios of 2 to 64 inclusive, Table 1 outlines the load values for the various divide ratios. Figure 4 presents the waveforms resulting from a divide by 37 operation. Note that the availability of the COUT complimentary output COUT allows the user to choose the polarity of the divide by output.

For single device programmable counters the E016 counter is probably a better choice than the E136. The E016 has an internal feedback to control the reloading of the counter, this not only simplifies board design but also will result in a faster maximum count frequency.

For programmable dividers of larger than 8 bits the

superiority of the E016 diminishes, and in fact for very wide dividers the E136 will provide the capability of a faster count frequency. This potential is a result of the cascading features mentioned previously in this document. Figure 5 shows the architecture of a 24-bit programmable divider implemented using E136 counters. Note the need for one external gate to control the loading of the entire counter chain. An ideal device for the external gating of this architecture would be the 4-input OR function in the 8-lead SOIC ECLinPS Lite™ family. However the final decision as to what device to use for the external gating requires a balancing of performance needs, cost and available board space. Note that because of the need for external gating the maximum count frequency of a given sized programmable divider will be less than that of a single cascaded counter.

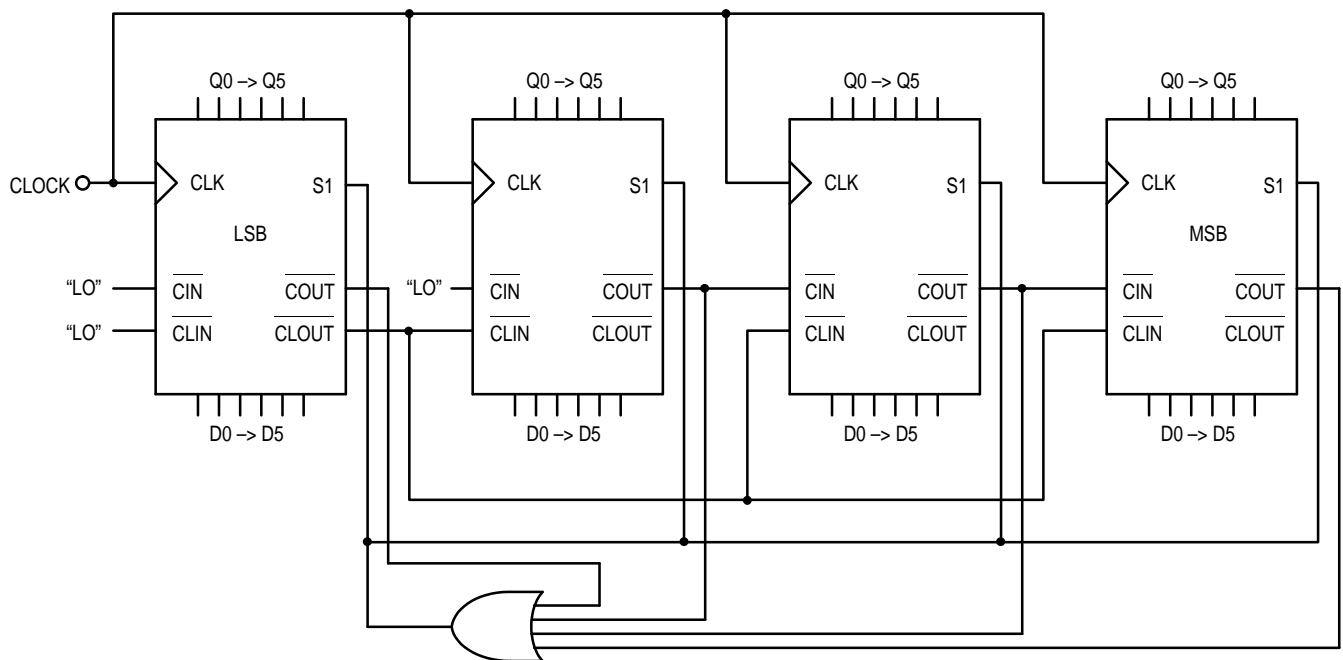
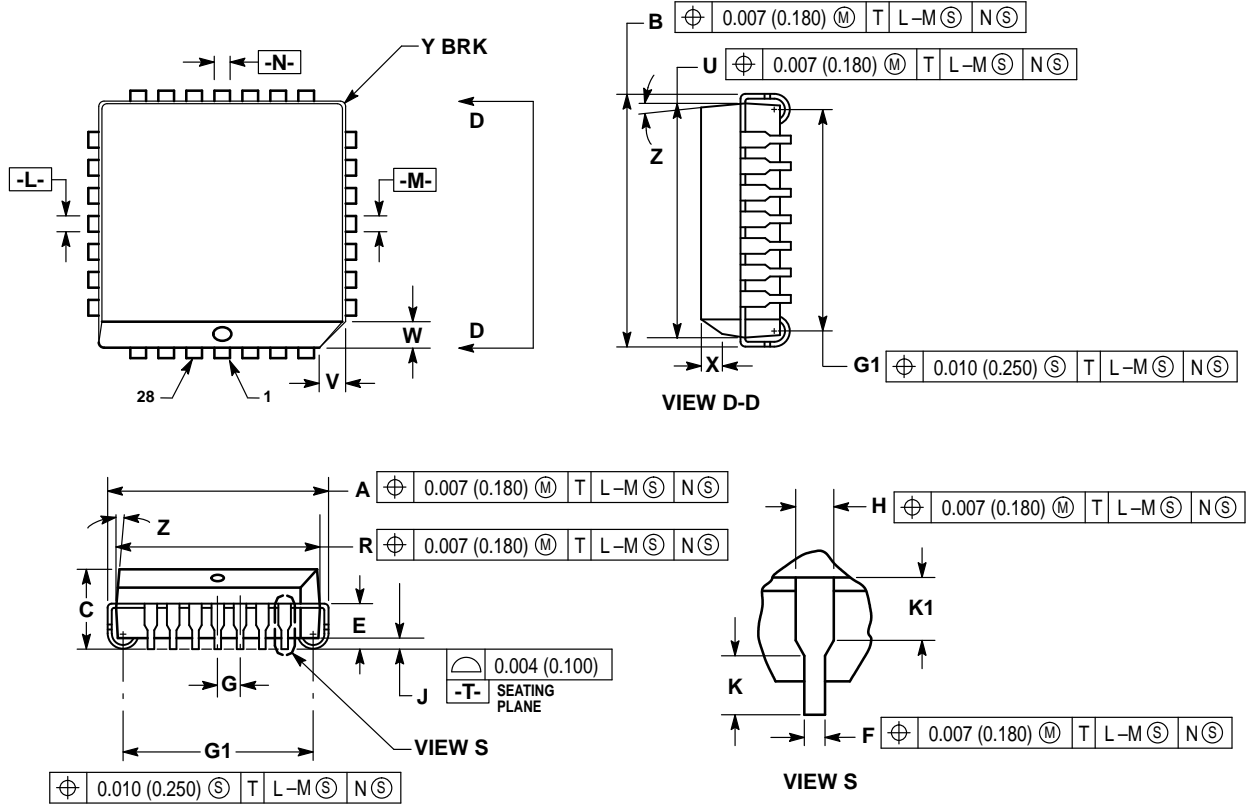

Figure 5. 24-bit Programmable Divider Architecture

OUTLINE DIMENSIONS

FN SUFFIX  
 PLASTIC PLCC PACKAGE  
 CASE 776-02  
 ISSUE D



NOTES:

- DATUMS -L-, -M-, AND -N- DETERMINED WHERE TOP OF LEAD SHOULDER EXITS PLASTIC BODY AT MOLD PARTING LINE.
- DIM G1, TRUE POSITION TO BE MEASURED AT DATUM -T-, SEATING PLANE.
- DIM R AND U DO NOT INCLUDE MOLD FLASH. ALLOWABLE MOLD FLASH IS 0.010 (0.250) PER SIDE.
- DIMENSIONING AND TOLERANCING PER ANSI Y14.5M, 1982.
- CONTROLLING DIMENSION: INCH.
- THE PACKAGE TOP MAY BE SMALLER THAN THE PACKAGE BOTTOM BY UP TO 0.012 (0.300). DIMENSIONS R AND U ARE DETERMINED AT THE OUTERMOST EXTREMES OF THE PLASTIC BODY EXCLUSIVE OF MOLD FLASH, TIE BAR BURRS, GATE BURRS AND INTERLEAD FLASH, BUT INCLUDING ANY MISMATCH BETWEEN THE TOP AND BOTTOM OF THE PLASTIC BODY.
- DIMENSION H DOES NOT INCLUDE DAMBAR PROTRUSION OR INTRUSION. THE DAMBAR PROTRUSION(S) SHALL NOT CAUSE THE H DIMENSION TO BE GREATER THAN 0.037 (0.940). THE DAMBAR INTRUSION(S) SHALL NOT CAUSE THE H DIMENSION TO BE SMALLER THAN 0.025 (0.635).

| DIM | INCHES    |       | MILLIMETERS |       |
|-----|-----------|-------|-------------|-------|
|     | MIN       | MAX   | MIN         | MAX   |
| A   | 0.485     | 0.495 | 12.32       | 12.57 |
| B   | 0.485     | 0.495 | 12.32       | 12.57 |
| C   | 0.165     | 0.180 | 4.20        | 4.57  |
| E   | 0.090     | 0.110 | 2.29        | 2.79  |
| F   | 0.013     | 0.019 | 0.33        | 0.48  |
| G   | 0.050 BSC |       | 1.27 BSC    |       |
| H   | 0.026     | 0.032 | 0.66        | 0.81  |
| J   | 0.020     | —     | 0.51        | —     |
| K   | 0.025     | —     | 0.64        | —     |
| R   | 0.450     | 0.456 | 11.43       | 11.58 |
| U   | 0.450     | 0.456 | 11.43       | 11.58 |
| V   | 0.042     | 0.048 | 1.07        | 1.21  |
| W   | 0.042     | 0.048 | 1.07        | 1.21  |
| X   | 0.042     | 0.056 | 1.07        | 1.42  |
| Y   | —         | 0.020 | —           | 0.50  |
| Z   | 2°        |       | 10°         |       |
| G1  | 0.410     | 0.430 | 10.42       | 10.92 |
| K1  | 0.040     | —     | 1.02        | —     |



Motorola reserves the right to make changes without further notice to any products herein. Motorola makes no warranty, representation or guarantee regarding the suitability of its products for any particular purpose, nor does Motorola assume any liability arising out of the application or use of any product or circuit, and specifically disclaims any and all liability, including without limitation consequential or incidental damages. "Typical" parameters which may be provided in Motorola data sheets and/or specifications can and do vary in different applications and actual performance may vary over time. All operating parameters, including "Typicals" must be validated for each customer application by customer's technical experts. Motorola does not convey any license under its patent rights nor the rights of others. Motorola products are not designed, intended, or authorized for use as components in systems intended for surgical implant into the body, or other applications intended to support or sustain life, or for any other application in which the failure of the Motorola product could create a situation where personal injury or death may occur. Should Buyer purchase or use Motorola products for any such unintended or unauthorized application, Buyer shall indemnify and hold Motorola and its officers, employees, subsidiaries, affiliates, and distributors harmless against all claims, costs, damages, and expenses, and reasonable attorney fees arising out of, directly or indirectly, any claim of personal injury or death associated with such unintended or unauthorized use, even if such claim alleges that Motorola was negligent regarding the design or manufacture of the part. Motorola and  are registered trademarks of Motorola, Inc. Motorola, Inc. is an Equal Opportunity/Affirmative Action Employer.

**How to reach us:**

**USA/EUROPE/Locations Not Listed:** Motorola Literature Distribution;  
P.O. Box 20912; Phoenix, Arizona 85036. 1-800-441-2447 or 602-303-5454

**MFAX:** RMFAX0@email.sps.mot.com – TOUCHTONE 602-244-6609  
**INTERNET:** <http://Design-NET.com>

**JAPAN:** Nippon Motorola Ltd.; Tatsumi-SPD-JLDC, 6F Seibu-Butsuryu-Center,  
3-14-2 Tatsumi Koto-Ku, Tokyo 135, Japan. 03-81-3521-8315

**ASIA/PACIFIC:** Motorola Semiconductors H.K. Ltd.; 8B Tai Ping Industrial Park,  
51 Ting Kok Road, Tai Po, N.T., Hong Kong. 852-26629298

